

# Wireless Sensor Network Based Server Room Temperature Monitoring System

Reza Nandika <sup>a,1\*</sup>, Era Madona <sup>a,2</sup>, Laxsmy Devy <sup>a,3</sup>, Adi Chandranata <sup>a,4</sup>, Yultrisna <sup>a,5</sup>

<sup>a</sup> Department of Electrical Engineering, Politeknik Negeri Padang, Indonesia

<sup>1</sup> reza@pnp.ac.id

\* corresponding author

## ABSTRACTS

A remote temperature monitoring system has been created in the server room using LoRa technology which is based on preventing overheating on servers which can affect the performance of components in the server. The research objective is to design and implement a new LoRa-based server room monitoring system design. The targets of this research are (a) creating a system prototype, (b) programming the system with the help of Arduino IDE, (c) measuring system performance. The research method starts from making a prototype and measuring system performance. The results of system performance measurements, testing on LoRa showed the best RSSI results of -56 dBm, temperature data from 17°C -19°C and humidity from 55% to 59% in the server room. Overall the tool can function well.

## ARTICLE INFO

### Article history

Received April 5, 2023

Revised May 19, 2023

Accepted June 30, 2023

### Keywords

LoRa, DHT-11, NodeMCU  
ESP32, Arduino Nano,  
Wireless Sensor Network

## 1. INTRODUCTION

The development of information technology is currently growing, marked by the easier it is to communicate long distances, send files to clients in a short time, search for information using search engines quickly. All of this can be done because of the existence of a system that regulates the flow of information, serves requests, and provide a database. A server is a computer system that serves and controls access to clients connected to it. All activities carried out on the internet always involve a server [1] [2]. The server plays a very important role, therefore, the server must not experience interference. However, there are times when the server's performance can be disrupted. One of the reasons is that when the server overheats, its performance will decrease. Apart from overheating, the influencing factor is the humidity of the server room, high humidity in the room will affect the performance of the components in the server [3][4]. Therefore, there is a need for a room temperature monitoring system that can be monitored remotely. One of the solutions that can be used to deal with the above problems is by utilizing Internet of Things (IoT) technology [5][6].

By using IoT, a sensor can collect data from a place and can access it remotely. This makes it possible to monitor room temperature remotely via electronic devices. So that information from the room temperature sensor can be sent to electronic devices, a communication module is needed [7]. The communication modules used include ZigBee [8], NRF24L01 [9] and LoRa [10] all of which can be used in the same IoT system. ZigBee and NRF24L01 can be used for high data speed applications but have limitations on distance, the average data sent remains stable from a distance of 10 meters to 300 meters with an average of 80-90% of data successfully sent, and the connection will only be lost at a distance 400 meters [11]. On the other hand, LoRa can be used for low power, applications that require longer distances and lower data rates [12]. Based on these problems, this research developed a remote temperature monitoring system in the server room by utilizing LoRa technology to be more effective in monitoring the temperature in the server room.

Research related to monitoring room temperature has been carried out previously, such as monitoring temperature and humidity in hydroponic plants in real time based on a wireless sensor network (WSN) [13] using an xbee module as a wireless communication device, the sensor data is then displayed on the LCD. The research results show that the xbee range is 70 meters. Other research involves making a prototype for a Zigbee-based water level and temperature monitoring system [14]. Fabricated prototype assisted by ultrasonic sensor and LM35 sensor for water level and temperature detection, xbee Pro module for communication module. The research results show that the effective distance that can be reached by the communication module between the microcontroller system and the personal computer (PC) is 20 meters. Similar research for WSN-based smart home monitoring [15] uses a Bluetooth module for the communication module and the MQ-05 gas leak sensor. For the user interface, use Android. The research results show that the monitoring tool works well, the use of the Bluetooth module in this research means the range is not optimal. Based on a number of research results, a monitoring system for monitoring temperature and humidity in the server room was manufactured. The system designed consists of an Arduino nano microcontroller as the main processor, a DHT11 temperature and humidity sensor,

LoRa for the communication module with a NodeMCU ESP32 Wifi-based gateway. The system is monitored using a mobile web-based application. By designing this system the aim is to provide a comfortable and practical way for users to monitor the condition of the server room.

## 2. RESEARCH METHODOLOGY

### A. System Description

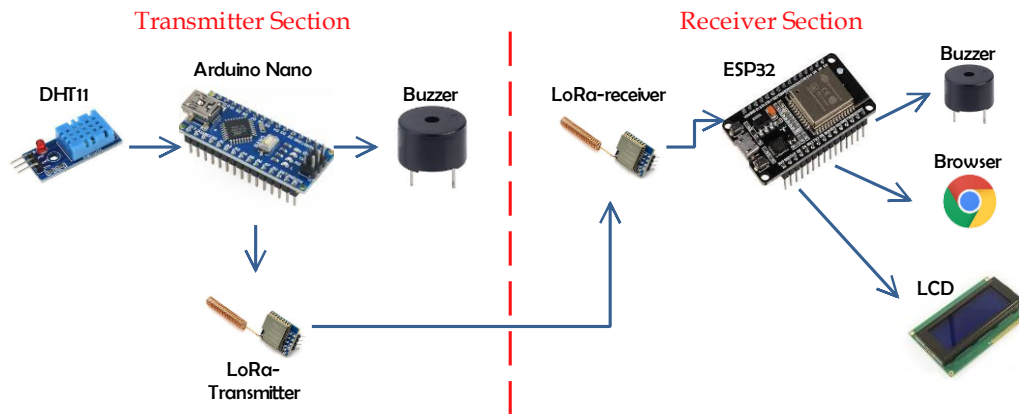

FIG 1. Block diagram system

Based on Figure 1, the system created is divided into three parts, namely Arduino Nano, NodeMCU ESP32 and LoRa. The input from this tool is DHT-11. The DHT-11 sensor is processed by Arduino Nano and sent to the buzzer. The buzzer will sound if the server room temperature is too hot or too cold, and stops sounding if the server room temperature is normal. The reading results that have been processed by the Arduino Nano are then sent to the NodeMCU ESP32 using LoRa communication. In this tool, two LoRa units are used, each on the transmitter and receiver. Next, the data from the sensor is displayed on the LCD and browser. The LCD and browser display the temperature and humidity of the server room.

### B. Hardware Design

The system consists of Arduino nano as a microcontroller, DHT11 temperature and humidity sensor, LoRa as a communication module and NodeMCU as a gateway. The electronic circuit of the system being developed is shown in Figure 2.

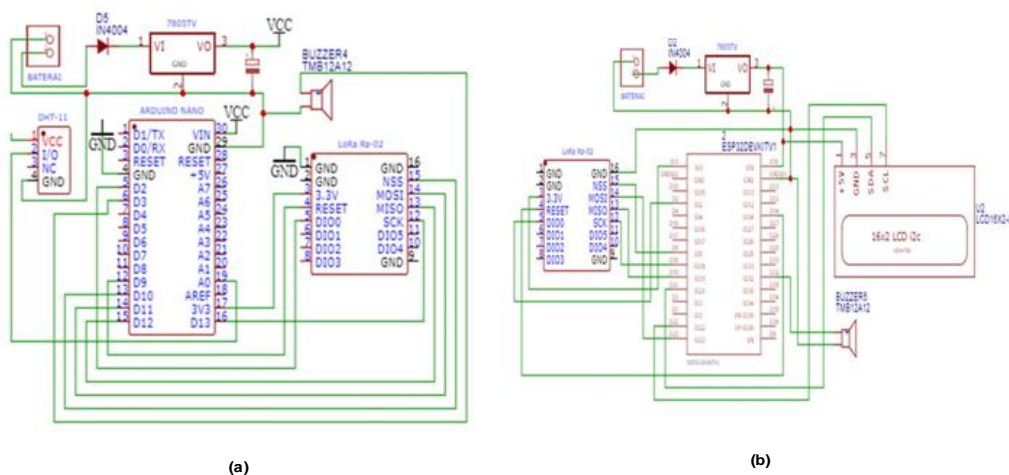

FIG 2. (a ) electronic circuit part transmitter, (b ) electronic circuit of the receiver section

Based on Figure 2, it can be explained that the circuit made consists of two parts, namely the transmitter and receiver parts. The Data Pin on DHT11 (transmitter section) is connected to Pin A0 on the Arduino nano. The positive pin on the buzzer is connected to Pin D6 on the Arduino Nano for the Data Pin, the data is sent in digital form. in RST, NSS, MOSI, MISO, and SCK on the LoRa transmitter are connected to pins D9, D10, D11, D12, and D13 on the Arduino Nano while Pin DIO0 on the LoRa transmitter is connected to pin D2 on the Arduino Nano, Pin VCC and GND LoRa transmitter connected to the VCC and GND pins on the Arduino Nano. Next, in the LoRa receiver section, the RST, NSS, MOSI, MISO, and SCK pins on the LoRa receiver are connected to the IO14, IO5, IO23, IO19, and IO18 pins on the ESP32 NodeMCU while the DIO0 pin on the LoRa receiver connected to the IO2 pin on the ESP32 NodeMCU, the LoRa receiver's VCC and GND pins are connected to the VCC (3V3) and GND pins on the ESP32 NodeMCU. Meanwhile, 4 PINs are used on the LCD, namely VCC, GND, SDA and SCL. The VCC and GND pins are connected to the customized pins on the NodeMCU ESP32, the SDA Pin is connected to the IO21 Pin and the SCL Pin is connected to the IO22 Pin. The overall system table is shown in Table 1.

TABLE 1. Overall System

	Input	Output	Condition
DHT 11	Temperature > 27°C	Browser	Server room temperature conditions : Hot!
	18°C - 27°C		Server room temperature conditions : Normal
	Temperature < 18°C		Server room temperature conditions : Cold
	DHT-11 on LoRa	LCD and Browser	Display dht-11 reading on lcd and browser Temperature : °C Humidity : %
DHT 11	Temperature > 27°C	Buzzer	ON
	18°C - 27°C		OFF
	Temperature < 18°C		ON

**B. Software Design**

Software design is carried out to form instructions that will be used in the tool's work system. In designing software, the first thing to do is create a program algorithm. The program algorithm in the form of a flowchart is shown in Figure 3.

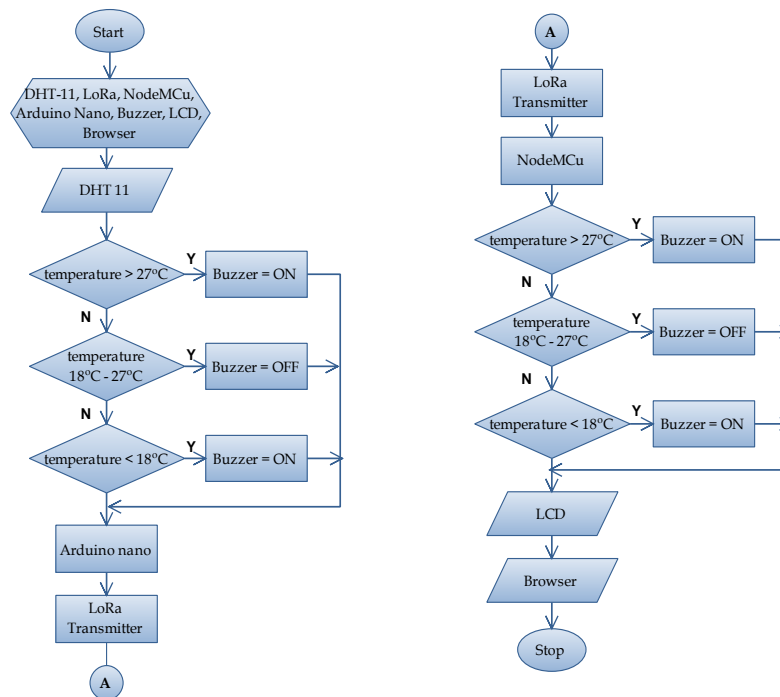

FIG 3. Flowchart chain lora transmitter and lora receiver

Based on Figure 3, the DHT-11 sensor as a temperature and humidity detector is in the LoRa transmitter circuit, the results of the readings are processed by the Arduino Nano and the DHT-11 sensor is created in three conditions, namely when the temperature is  $>27^{\circ}\text{C}$  then when the server room is too hot the buzzer "ON", then if the temperature range is  $18^{\circ}\text{C} - 27^{\circ}\text{C}$  then when the server room is normal the buzzer is "OFF", and the last condition is if the temperature is  $<18^{\circ}\text{C}$  then when the server room is too cold the buzzer is "ON". After being processed by the Arduino Nano, the readings will be sent by LoRa via radio waves from the LoRa receiver circuit then the NodeMCU ESP32, then the reading results are sent to the buzzer. The temperature and humidity data that has been processed by the NodeMCU ESP32 is then displayed on the LCD and browser.

### 3. RESULTS AND DISCUSSION

Based on the specifications and design that have been determined, the tool prototype is shown in Figure 4.

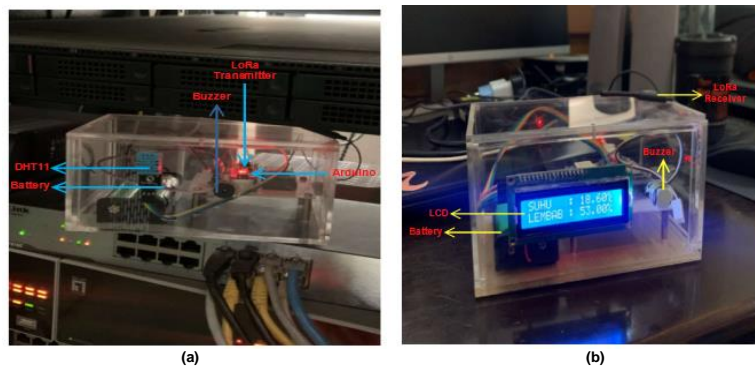

FIG 4. Prototype server temperature monitoring tool (a) LoRa Transmitter, (b) LoRa Receiver

Next, device testing is carried out to see the performance of the tool. Testing in this research focuses on testing RSSI values on LoRa and testing data transmission on IoT. The main goal of testing RSSI values on LoRa is to evaluate the quality and reliability of wireless communications between LoRa devices in various environmental conditions and settings. The testing point on LoRa is shown in Figure 5. Testing the RSSI value on LoRa is the process of measuring the strength of the radio signal received from other LoRa devices. RSSI is a metric that indicates how strong or weak the signal received by the receiver from the sender. The RSSI value is generally expressed as a number in decibel units (dBm) and provides an idea of the strength of the radio signal at the receiving device. The average RSSI can be determined through equation 1: The RSSI value can be divided into several levels as shown in Table 2. The results of testing the RSSI value are shown in Table 3

$$\text{Average RSSI} = \frac{\text{Number of rssi values}}{\text{package received}} \dots\dots\dots(1)$$

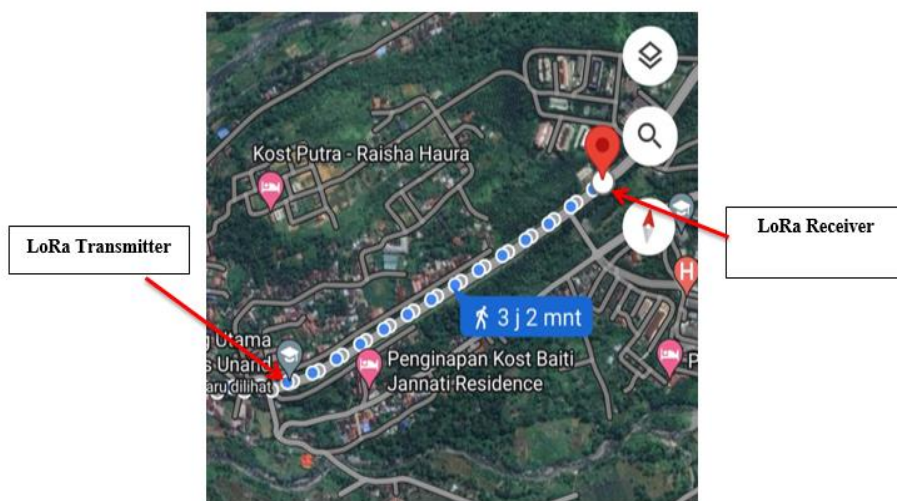

FIG 5. LoRa testing point area

TABLE 2. RSSI Value Levels

Level RSSI (dBm)	Information
-30 ~ -60	Very strong. The distance between the transmitter and receiver is very close
-60 ~ -90	Very good. Close coverage.
-90 ~ -105	Good. There is some data that is not received.
-105 ~ -115	Bad. Can accept but often drops out.
-115 ~ -120	Very bad. Weak signal, data is often lost.

TABLE 3. LoRa Communication RSSI Test Results

Distance (m)	RSSI Value (dBm)	Average RSSI (dBm)	Information
20	-74	-75	Very Good
	-77		
	-73		
	-75		
	-75		
	-75		
	-76		
	-76		
	-74		
	-75		
	-76		
	-74		
	50		
-78			
-80			
-80			
-81			
-82			
-82			
-83			
-77			
-75			
-80			
100	-83	-82,7	Very Good
	-83		
	-81		
	-82		
	-82		
	-83		
	-83		
	-84		
	-81		
	-82		
	-85		
150	-90	-93,9	Good
	-92		
	-95		
	-95		
	-94		
	-93		
	-93		
	-94		
	-94		

	-95		
	-95		
	-97		
300	-95	-99,5	Good
	-95		
	-97		
	-96		
	-101		
	-100		
	-103		
	-97		
	-99		
	-105		
	-102		
	-104		
400	0	0	Sinyal Loss

Based on Table 3, the highest average RSSI value is -75dBm at a distance of 20 meters, while the lowest average RSSI value is -99.5dBm at a distance of 300m, while at a distance of 400 meters LoRa cannot receive the data sent. LoRa can receive data very well at a distance of 0-100 meters, when the distance is 150 to 300 meters there is some that is received. From this test, it can be seen that the LoRa position affects data transmission and is also affected by buildings and trees that are in the position of the LoRa receiver and transmitter.

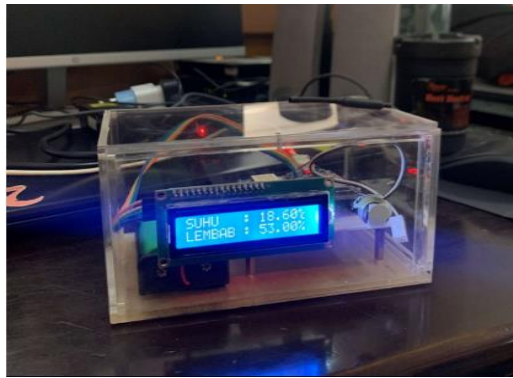

FIG 6. LCD display on the LoRa Receiver

In figure 6, the LCD display on the LoRa receiver that receives data from the DHT-11 sensor is on the LoRa transmitter and the data is sent to the LoRa receiver. Based on Figure 6, the temperature and humidity during testing were 18.70°C and 54%. DHT 11 has a total of 40 bits of data with data division including the first 8 bits for High Humidity, the second 8 bits for Low Humidity, the third 8 bits for High Temperature, the fourth 8 bits for Low Temperature and the last 8 bits for Parity or the sum of the previous 36 data bits.

#### 4. CONCLUSIONS

Based on the results and discussion in accordance with the research objectives, it can be concluded. Making devices for monitoring temperature and humidity in LoRa-based server rooms is carried out in stages (i) making circuits and placing sensors, (ii) making device prototypes, (iii) determining input, output pins and algorithms. The highest average RSSI value is -75dBm at a distance of 20 meters, while the lowest average RSSI value is -99.5dBm at a distance of 300m, while at a distance of 400 meters LoRa cannot receive the data sent. LoRa can receive data very well at a distance of 0-100 meters, when the distance is 150 to 300 meters there is some that is received. From this test, it can be seen that the LoRa position affects data transmission and is also affected by buildings and trees that are in the position of the LoRa receiver and transmitter.

## REFERENCES

- [1] P. Bellavista, J. Berrocal, A. Corradi, S. K. Das, L. Foschini, and A. Zanni, "A survey on fog computing for the Internet of Things," *Pervasive Mob. Comput.*, vol. 52, pp. 71–99, 2019, doi: 10.1016/j.pmcj.2018.12.007.
- [2] D. J. Langley, J. van Doorn, I. C. L. Ng, S. Stieglitz, A. Lazovik, and A. Boonstra, "The Internet of Everything: Smart things and their impact on business models," *J. Bus. Res.*, vol. 122, no. June 2018, pp. 853–863, 2021, doi: 10.1016/j.jbusres.2019.12.035.
- [3] K. M. U. Ahmed, M. H. J. Bollen, and M. Alvarez, "A Review of Data Centers Energy Consumption and Reliability Modeling," *IEEE Access*, vol. 9, pp. 152536–152563, 2021, doi: 10.1109/ACCESS.2021.3125092.
- [4] M. O. Onibonoje, P. N. Bokoro, N. I. Nwulu, and S. L. Gbadamosi, "An IoT-Based Approach to Real-Time Conditioning and Control in a Server Room," *2019 Int. Conf. Artif. Intell. Data Process. Symp. IDAP 2019*, 2019, doi: 10.1109/IDAP.2019.8875880.
- [5] M. Alvan Prastoyo Utomo, A. Aziz, Winarno, and B. Harjito, "Server Room Temperature & Humidity Monitoring Based on Internet of Thing (IoT)," *J. Phys. Conf. Ser.*, vol. 1306, no. 1, pp. 0–8, 2019, doi: 10.1088/1742-6596/1306/1/012030.
- [6] P. P. Kulkarni, M. Patil, S. Shibi, M. Patle, and R. Kale, "Review on Online Monitoring of Electrical Machine using IOT," *2019 Int. Conf. Nascent Technol. Eng. ICNTE 2019 - Proc.*, no. Icn-te, 2019, doi: 10.1109/ICNTE44896.2019.8945927.
- [7] C. Bayılmış, M. A. Ebleme, Ü. Çavuşoğlu, K. Küçük, and A. Sevin, "A survey on communication protocols and performance evaluations for Internet of Things," *Digit. Commun. Networks*, vol. 8, no. 6, pp. 1094–1104, 2022, doi: 10.1016/j.dcan.2022.03.013.
- [8] S. Maung, S. Shiraje, A. Islam, M. M. Hossain, S. Nahar, and M. F. H. Arif, "Optimization of ZigBee Network Parameters for the Improvement of Quality of Service," *J. Comput. Commun.*, vol. 06, no. 06, pp. 1–14, 2018, doi: 10.4236/jcc.2018.66001.
- [9] A. C. Bento, E. M. L. Da Silva, and E. M. De Souza, "An Experiment with NRF24L01+ and Arduino Pro Micro Data Transmission for IoT," *2019 10th Int. Conf. Comput. Commun. Netw. Technol. ICCCNT 2019*, no. July 2020, 2019, doi: 10.1109/ICCCNT45670.2019.8944813.
- [10] M. H. Widiyanto, "Journal of Software Engineering , Information and Communication Technology ( SEICT ) Systematic Literature Review : LoRa and LoRaWAN Projects in Practice," vol. 3, no. 1, pp. 25–34, 2022.
- [11] A. Martínez, E. Cañibano, and J. Romo, "Analysis of low cost communication technologies for V2I applications," *Appl. Sci.*, vol. 10, no. 4, 2020, doi: 10.3390/app10041249.
- [12] A. I. Ali and S. Zorlu Partal, "Development and performance analysis of a ZigBee and LoRa-based smart building sensor network," *Front. Energy Res.*, vol. 10, no. August, pp. 1–13, 2022, doi: 10.3389/fenrg.2022.933743.
- [13] A. B. Emge, I. Afrianto, and S. Atin, "Temperature and Humidity Monitoring System using Wireless Based Xbee on Hydroponic Plants," *IOP Conf. Ser. Mater. Sci. Eng.*, vol. 879, no. 1, 2020, doi: 10.1088/1757-899X/879/1/012097.
- [14] A. K. Dewi, A. A. B. A. Sahaya, and W. Sugiman, "Level and Temperature Monitoring System in Blending Process Using Zigbee Wireless Sensor Network," vol. 436, pp. 372–375, 2020, doi: 10.2991/assehr.k.200529.077.
- [15] T. Adiono, M. Y. Fathany, S. Fuada, I. G. Purwanda, and S. F. Anindya, "A portable node of humidity and temperature sensor for indoor environment monitoring," *IGBSG 2018 - 2018 Int. Conf. Intell. Green Build. Smart Grid*, pp. 1–5, 2018, doi: 10.1109/IGBSG.2018.8393575.